

Titan 700 Ltr Rainstore

Codes: RW700GR (Green)
RW700GT (Granite)
RW700SS (Sandstone)

Description

* A large capacity (700 Ltr) domestic rainwater storage tank for the serious water user.

* Available in Green, Granite & Sandstone.

Note: The green tank is standard with a green lid & the granite/sandstone tanks are standard with a black lid.

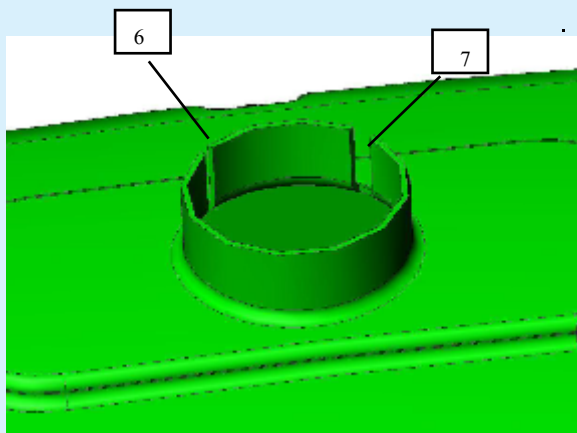
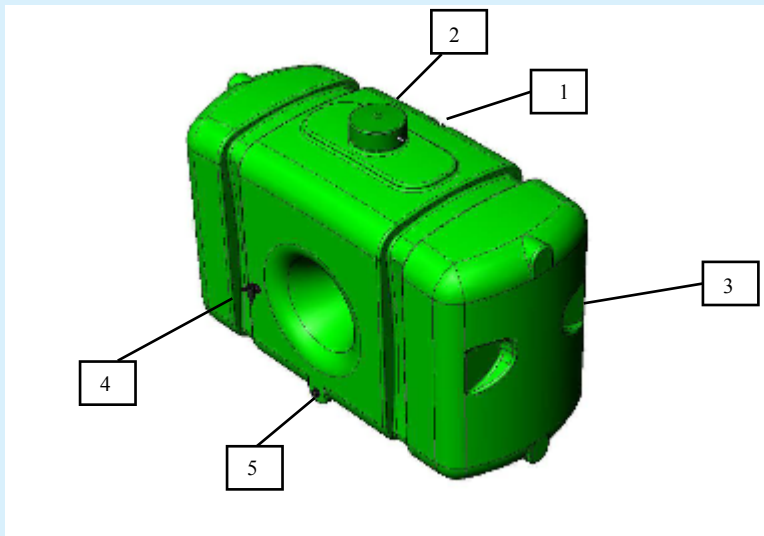

Features

1. Downpipe Diverter Kit (No Filter)
2. 7" Lid
3. Lifting Handles
4. 3/4" BSP Tap
5. 3/4" BSP Tank Bung
6. Slot for submersible pump power cord (optional)
7. Slot for garden hose (optional)

Installation Kit Contents (Supplied with the tank)

1. Diverter Kit
2. Diverter Kit Hose
3. Diverter Kit Boss
4. Diverter Kit Installation Instructions
5. 3/4" BSP Bung
6. 3/4" BSP Tap
7. Tank Installation Instructions



How It Works

1. Rainwater is fed into the tank from the downpipe using the included diverter.
2. The 7" lid can be removed for cleaning purposes. Fittings instructions & parts enclosed under lid.
3. Lifting handles on both ends of tank.
4. The tank is supplied with a 3/4" BSP tap and 3/4" BSP tank bung. Both fittings should be fitted on the front face of the tank. The fittings are interchangeable.
5. The tank neck has a 170mm aperture. This allows a submersible pump to be fitted into the tank.
6. Guide lines have been provided on the tank upstand to allow the end user to cut submersible pump slots if required.

Tank needs to be positioned on a fully supported base.



Technical Data

Dimensions:

Length: 1500mm

Height: 978mm

Width: 650mm

Internal Neck Diameter: 170mm

Capacity: 700 Ltr

Material: Polyethylene

Guarantee Period: 1 Year

Tap & bung to be fitted after delivery.

Note: Optional Diverter Kit with filter available.

Sales Information

Quantity per load: 48

Availability Date: In Stock

Quantity Per Pallet: 3

Site of Manufacture: Portadown

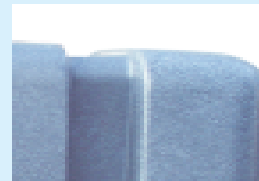

RW700GT (Granite)

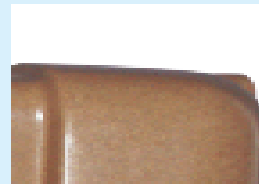

RW700SS (Sandstone)

Titan Environmental Ltd, Seapatrick Road, Seapatrick,
Banbridge, Co Down, BT32 4PH
Tel: +44 (0) 28 4062 6260 Fax: +44 (0) 28 4062 6259
sales@titanenv.com www.titanenv.com

the Power Behind
TITAN